



Dust Control and Loading Systems Inc

*Leaders in Innovative Bulk Loading Systems Design*

## Aeration Equipment

**CONVEYORS ● BIN BOTTOMS ● LUMP TRAPS  
TROUGHS ● SILO PENETRATION ADAPTORS  
ROTARY THROTTLE & VERTICAL SLIDE GATE VALVES  
TURNING BOXES ● SILO & DOME FLOORS**



Jamieson Equipment Company  
www.jamiesonequipment.com  
toll free 800.875.0280



*Aerated bin bottom discharging into a conveyor with slide gate valves.*



*Aerated distribution box with four discharges.*



*Aeration conveyor run.*



*Aerated lump trap with slide gate valve.*



*Aeration conveyors feeding multiple silos.*



## AERATION EQUIPMENT OVERVIEW

Under normal conditions a powder runs down a chute only when the slope exceeds the natural angle of repose of the powder. A fluidized powder however, runs down a chute which has an angle much less than the natural angle of repose of the powder. The principle of air gravity conveying involves the reduction of the natural angle of repose of a pulverized material to a fluidized angle which is slightly less than the angle of declination of the conveyor. This is accomplished by passing low pressure air through a porous membrane and into a bed of pulverized material.

A large variety of materials are handled on aeration conveyors regardless of their abrasive nature or bulk density. The only criteria is particle size and moisture. Generally, a product should have a particle distribution of 100% through a 20 mesh screen. It is possible to convey coarser materials provided there is a greater percentage of fine material to fill the voids. Free moisture content should be below 1%, however materials with higher moisture contents have been conveyed. With some materials, the characteristics of particles may make aeration impossible or uneconomical. A powder that can be fluidized usually possess the characteristic of flowing freely through the fingers, feeling clean and dry, and not flaky or fibrous.



## AERATION CONVEYORS

Aeration conveyors are used to convey products from point A to point B by using aeration and gravity. Minimum suggested conveyor angle is 8 degrees, but may be as low as 6 degrees depending on product material type. Turning boxes, headchutes, and distribution boxes are available to use in conjunction with aeration conveyors.

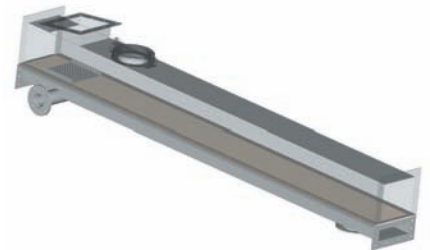

DCL offers a large selection of aeration conveyors from 6 inches [152 mm] wide up to 36 inches [914 mm] wide and conveying capacities up to 1000 cubic feet per minute [28.3 m<sup>3</sup>/min]. Conveyors also are available in a high top or low top design allowing for maximum flow rate or minimum head room depending on the application.



## AERATED LUMP TRAPS

Aeration lump traps are an ideal when large lumps are present in material. Lumps are generally created in the silo by moisture and are typically unacceptable for the consumer's vehicle being loaded. The lump trap eliminates large lumps by creating a gravity trap in-line with an aeration conveyor. This is accomplished by passing low pressure air through an overlapping configuration of porous membrane media and into the bed of the material being handled. Heavy lumps fall and are caught in the bottom of the lump trap which automatically empties using a level sensor accompanied by a series of slide gate valves.

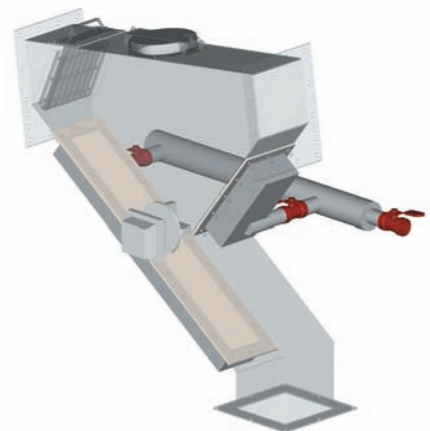

DCL offers a selection of aeration lump traps from 6 inches [152 mm] wide up to 36 inches [914 mm] wide and conveying capacities up to 1000 cubic feet per minute [28.3 m<sup>3</sup>/min]. Lump traps are also available in a high top or low top design allowing for maximum flow rate or minimum head room depending on the application.





## AERATED BIN BOTTOMS AND TROUGHS

Aeration bin bottoms are used to promote consistent product withdrawal from large diameter flat or conical bottom storage silos.

DCL offers a large selection of aeration bin bottoms from 2 feet [610 mm] in diameter up to 16 feet [4.9 m] in diameter. Bin bottoms are also available with custom discharge configurations allowing for multiple conveyor runs from one silo.

Troughs are typically mounted inside the conical section of the silo and are equally spaced along a 360 degree pattern. However they can also be used in flat bottom silos and only require a 6 degree slope from the inner silo wall of the silo to the discharge point.

DCL offers a selection of aeration troughs from 6 inches [152 mm] wide up to 24 inches [610 mm] wide.

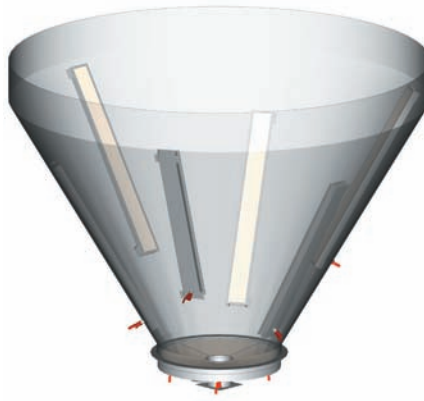

*Aerated bin bottom with side discharge and flow control valves.*



*Aeration conveyor being fed by bucket elevator.*



## SILO PENETRATION ADAPTORS

Aeration silo penetration adaptors allow material to be withdrawn from the side of any silo. They can be easily retrofitted in the field to existing silos when silo bottom discharges are not possible.

DCL offers a large selection of aeration silo penetration adaptors from 6 inches [152 mm] wide up to 36 inches [914 mm] wide and conveying capacities up to 1000 cubic feet per minute [28.3 m<sup>3</sup>/min].

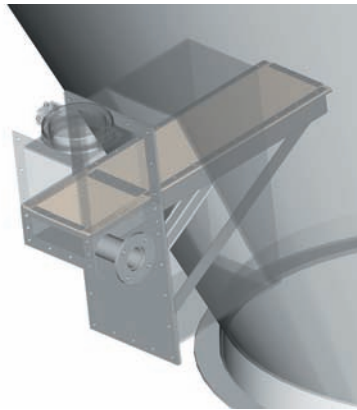

*Silo penetration adaptor with flow control valves feeding loadout station.*



## FLOW CONTROL VALVES

Rotary throttle valves are an excellent means to control material flow while air gravity conveying.

The rotary throttle valve uses a rotary parabolic blade that allows for a low profile design that delivers precise flow control. A 4-20m electric actuator is used to actuate the valve when real time infinite positioning is required. If real time infinite positioning is not required DCL uses a pneumatic actuator with a 3 position package.

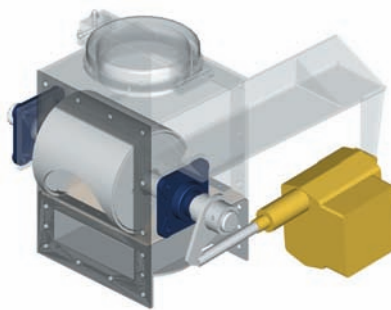
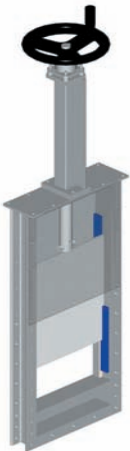

*Vertical manual and pneumatic slide gate valve.*

Vertical slide gate valves are used in applications where a material flow shut-off is required in air gravity conveying applications. The vertical slide gate uses a Blanchard ground chamfered blade. Not only can it be used to shut off material flow, it can also be used as a flow control.





## AERATED TURNING BOXES

Aerated turning boxes are used in conjunction with aeration conveyors allowing for turns in the conveyor run. Standard turning boxes are designed for 30, 45, and 90 degree turns. The degree of angle can be customized per the customers needs. Turning boxes are sized to the aeration conveyor being used in order to insure a proper flow rate.

DCL offers a large selection of aerated turning boxes from 6 inches [152 mm] wide up to 26 inches [914 mm] wide and conveying capacities up to 1000 cubic feet per minute [28.3 m<sup>3</sup>/min].



*Aeration conveyors distributing to multiple silos using a combination of turning boxes and vertical slide gates.*



## AERATED SILO / DOME FLOOR

DCL has made it possible to reclaim up to 99% of material in any sized silo or dome.

A DCL aerated floor can be either a side sloped or center sloped discharge design with live floor coverage dependent on the customer reclaim requirements and material type. Different material types require that the troughs be spaced within a maximum distance from each other.

DCL has learned from field experience that zone configuration is most important. Attention must be given to peripheral areas to avoid creating aerated surfaces that can become partially uncovered.

The aeration troughs are arranged in patterns which result in uncomplicated and simple plumbing procedures with all components installed above floor level (no buried trough, piping, or zone valving). When geometry dictates - wedge or other shaped sections are incorporated into the floor layout to fill unwanted voids.

One of the biggest advantages of the DCL system is that there are no moving parts. Also, there is a very limited time period that the aeration media is subject to activation with the exception of the discharge. Maintenance does not require that heavy equipment be moved into the dome. Only the aeration media itself should ever require attention. Should a single 10 foot aeration trough pad within a zone or an entire zone become non functional, reclaim would not likely be affected.

Another large advantage is that the DCL design power consumption requirements are much less than other designs on the market. This makes for significant energy savings.



*Aerated troughs for dome floor installation.*

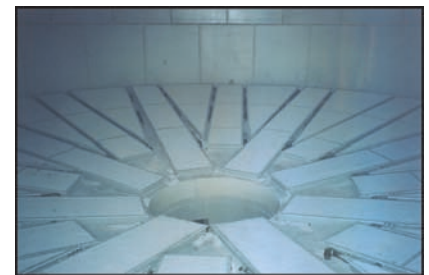

*30'-0" diameter fully aerated flat bottom silo using aeration troughs.*

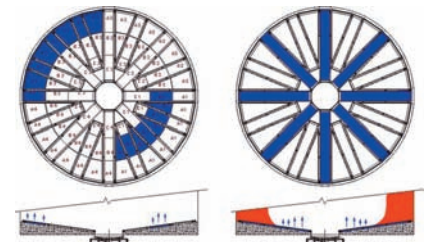

*The above left graphic shows the correct way to aerate a silo floor bottom with multiple concentrated zones. The above right graphic shows the incorrect way to aerate a silo floor bottom.*

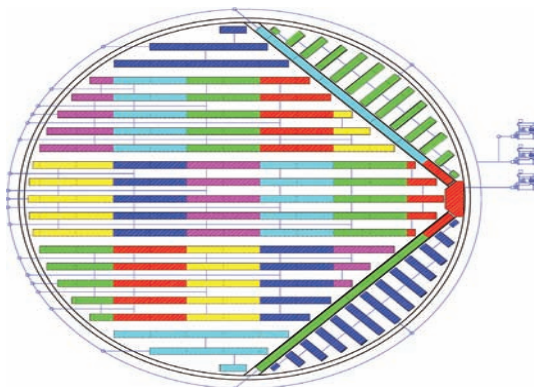

*The drawing to the left is a 120'-0" diameter dome with side discharge. This floor is sloped at 8 degree and has (22) individual zones. Piping is through side wall type with interconnecting troughs. Three 1000 CFM @ 10 PSI positive displacement blowers are used in pulsing sequence to empty dome. Aerated floor coverage is 33% with a 96% initial reclaim rate.*

*The drawing to the right is a 120'-0" diameter dome with center discharge. This floor is sloped at 8 degree and has (17) individual zones. Piping is through center tunnel with interconnecting troughs. Three 1000 CFM @ 10 PSI positive displacement blowers are used in pulsing sequence to empty dome. Aerated floor coverage is 26% with a 93% initial reclaim rate.*

